

User Manual

pE-400 Series: pE-400 and pE-400^{max}



Table of Contents

1. Introduction	3
2. Safety	3
2.1. pE-400 Series Warning Label	4
3. pE-400 Series Product Range	5
3.1. Light Source Models	5
3.2. Wavelength Variants	5
3.3. Light Delivery Variants	6
4. System Components	6
5. Reference Diagrams	7
5.1. pE-400 Light Sources	7
5.2. pE-400 ^{max} Light Sources	10
6. Installation	13
6.1. Mounting the Light Source	13
6.2. Electrical Connections	15
7. Light Source Control	16
7.1. Manual Control Pods	16
7.2. TTL Triggering	20
7.3. Software	21
7.4. pE-400 ^{max} LightBridge	21
7.5. Sequence Runner (pE-400 ^{max})	24
8. Excitation Filters (pE-400^{max})	27
8.1. Excitation Filter Installation Procedure	27
9. Optical Adjustment	29
10. Product Options and Order Codes	30
11. Warranty and Repairs	30
12. Compliance	30
12.1 WEEE	30
12.2 RoHS	30
13. Recycling	30
14. Contact Details	31
15. Product Specifications	31
16. Appendix	33
16.1. Boot Load Procedure	33

1. Introduction

Congratulations on the purchase of your new CoolLED pE-400 Series Illumination System. The pE-400 Series is a family of state-of-the-art four-wavelength LED Illumination Systems designed to meet the demands of cutting-edge microscopy applications.

This user manual provides all the information required for installation and safe operation. For additional details as well as other valuable LED illumination resources, please see the CoolLED website: www.cooled.com.

2. Safety

Warning: While LEDs are much safer than the mercury and metal halide lamps they replace, the following precautions must be taken when operating your pE-400 Series Illumination System. Failure to do so may result in permanent injury, damage to property or both.

- Only use the power supply and power cord provided to power the device. The supplied isolated power supply provides protective earthing.
- The Light Source is for Indoor use only.
- Never look directly into the output of the Light Source or attached accessories.
- The light can permanently damage the eye and may lead to blindness.
- Always ensure the Light Source is securely attached to the microscope before applying power to the device.
- If the Light Source must be operated while not attached to a microscope, all personnel must wear appropriate eye shielding and protective clothing. CoolLED strongly discourages using any CoolLED Light Source when not securely mounted to a microscope.
- If any pE-400 Series Illumination System is used in a manner not specified by this user manual, the protection provided by the equipment may be impaired.

Warning: Optical surfaces must only be cleaned with specifically designed optical wipes and purpose-formulated optical cleaning solutions. Failure to use optics-specific cleaning products may permanently damage the CoolLED Light Source.

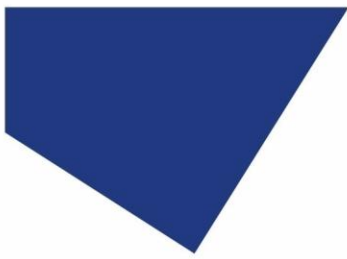

2.1. pE-400 Series Warning Label

Figure 1 - Risk Group Warning Label shows the Risk Group Warning Label on all pE-400 Series Light Sources. The label indicates that all pE-400 Series Light Sources fall into Risk Group 3 as defined by EN 62471 -2 "Photobiological safety of lamps and lamp systems – Part 2: Guidance on manufacturing requirements relating to non-laser optical radiation safety" standard. Risk Group 3 describes the highest risk group in terms of light exposure.

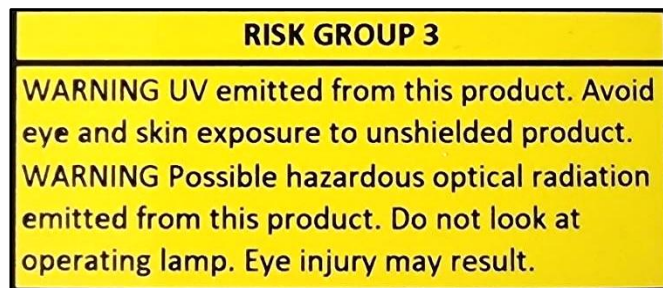

Figure 1: Risk Group 3 Warning Label

3. pE-400 Series Product Range

3.1. Light Source Models

The pE-400 Series includes two models: the pE-400 and the pE-400^{max}. The pE-400 is a simple, cost-effective white light source and controllable replacement for mercury and metal halide lamps. The pE-400^{max} permits the independent adjustment of channel irradiance and the ability to fit inline excitation filters.

3.2. Wavelength Variants

The pE-400 and pE-400^{max} can be purchased in two wavelength variations: Single-Band (SB) and Multi-Band (MB). The graph and Table 1 below detail the wavelengths available in the pE-400 Series and the respective channel number.

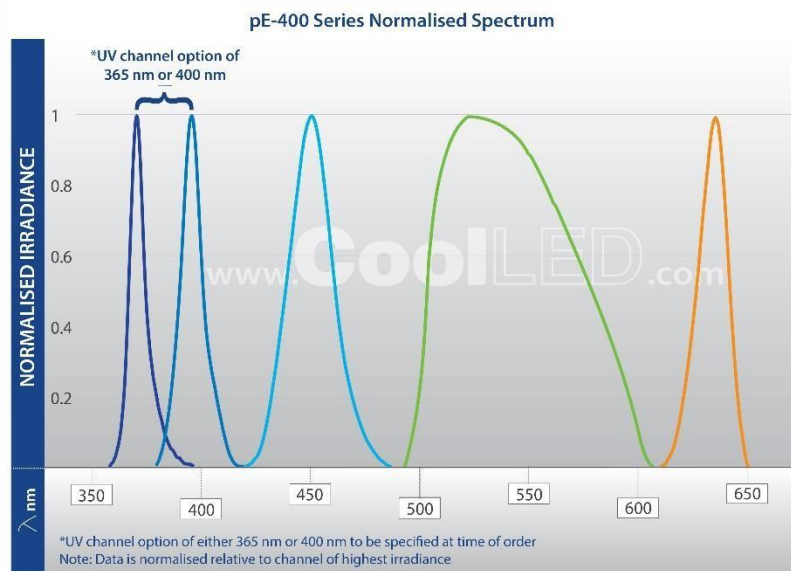

Wavelength Variant	Channel 1 Centre Wavelength (nm)	Channel 2 Centre Wavelength (nm)	Channel 3 Centre Wavelength (nm)	Channel 4 Centre Wavelength (nm)
Single-Band (SB)	365	450	550	635
Multi-Band (MB)	400	450	550	635

3.3. Light Delivery Variants

The pE-400 and pE-400^{max} are available with Direct Fit (DF) and Liquid Light Guide (LLG) output couplings. Direct Fit Light Sources (Figure 2) are designed to be secured directly to the epi-illumination arm of compatible microscopes, while liquid light guide units (Figure 3) accommodate a 3 mm light guide. The attached liquid light guide can be used as an input to an optional collimator or as a direct input to compatible microscopes.



Figure 2: Direct Fit output

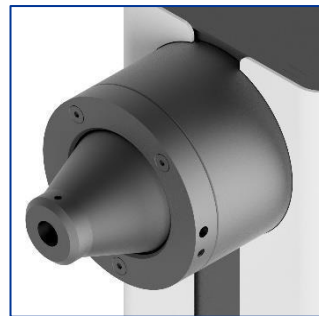

Figure 3: Liquid Light Guide output

4. System Components

pE-400 Series Illumination Systems include various components necessary to meet the demands of specific microscope installations. At a minimum, the pE-400 Series Illumination System includes the following:

- pE-400 Series Light Source
- pE-400 Series Control Pod
- Power supply
- 1.5 mm Hex Key required for installation



Figure 4: (clockwise) pE-400^{max} Control Pod, pE-400^{max} Light Source, 1.5 mm Hex Key, pE-400 Series Power Supply.

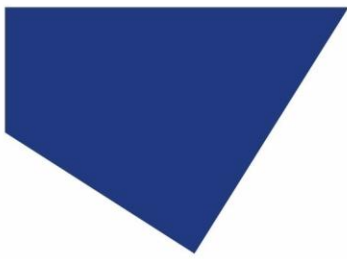

5. Reference Diagrams

5.1. pE-400 Light Sources

Direct Fit



Figure 5

Item	Description
1	Adaptor retention screws
2	Optical adjustment
3	On/off switch
4	Grounding terminal
5	Global TTL input (global shutter)
6	Control Pod socket
7	USB A socket
8	Power socket
9	Status indicator
10	Bootload switch

Table 1

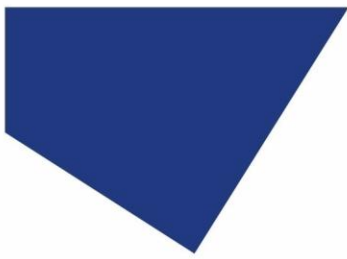

Liquid Light Guide

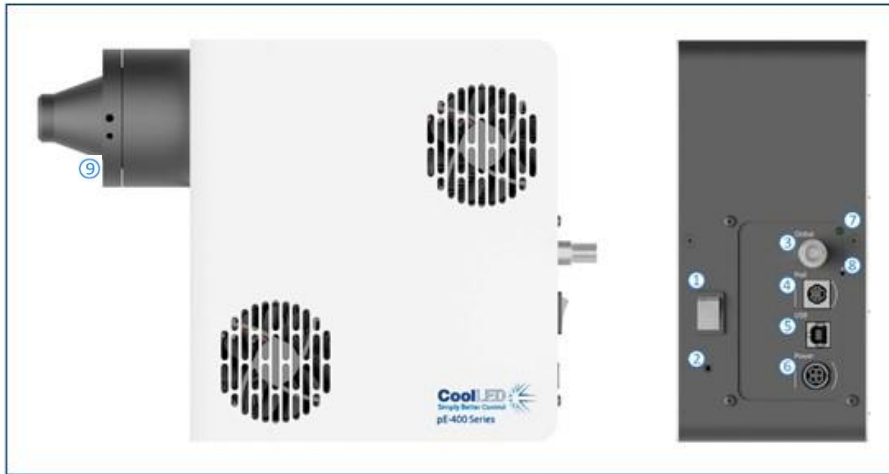
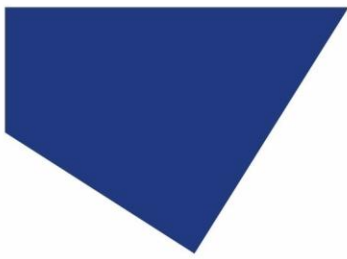

Figure 6

	Description
1	On/off switch
2	Grounding terminal
3	Global TTL input (global shutter)
4	Control Pod socket
5	USB A socket
6	Power socket
7	Status indicator
8	Bootload switch
9	Liquid light guide retention screws

Table 2



pE-400 Control Pod



Figure 7

Item	Button Description
1	Mode
2	On/off
3	Increase global irradiance
4	Decrease global irradiance

Table 3

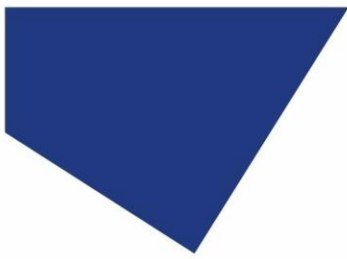

5.2. pE-400^{max} Light Sources

Direct Fit

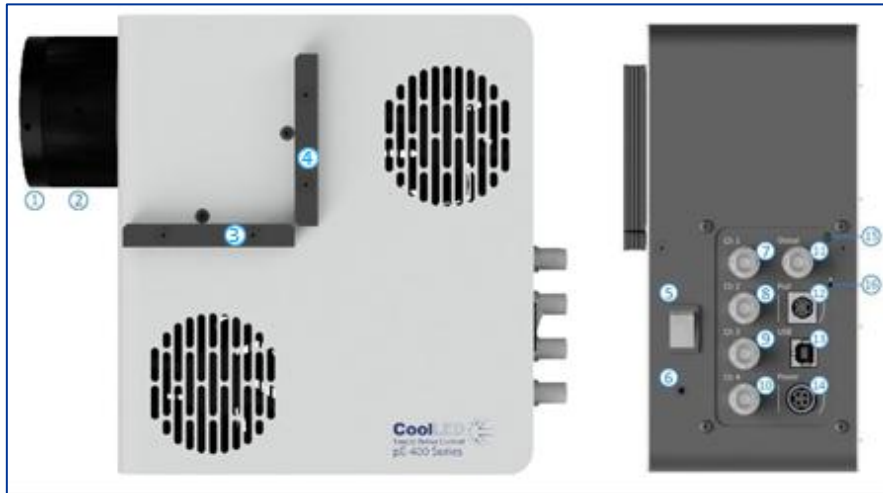
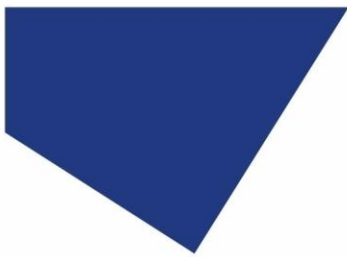

Figure 8

Item	Description
1	Adaptor retention screws
2	Optical adjustment
3	Filter slot 1 (filter holders sold separately)
4	Filter slot 2 (filter holds sold separately)
5	On/off switch
6	Grounding terminal
7	Channel TTL input 365/400 nm (channel shutter)
8	Channel TTL input 450 nm (channel Shutter)
9	Channel TTL input 550 nm (channel Shutter)
10	Channel TTL input 635 nm (channel Shutter)
11	Global TTL input (global shutter)
12	Control Pod socket
13	USB A socket
14	Power socket
15	Status indicator
16	Bootload switch

Table 4



Liquid Light Guide

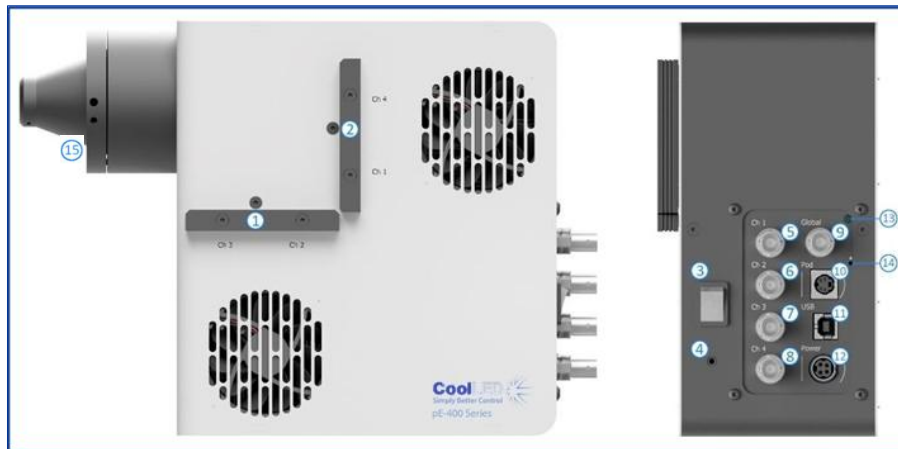
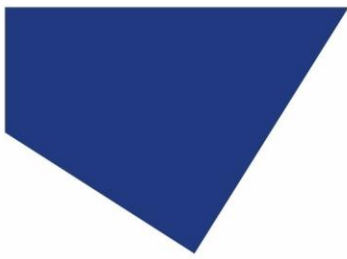

Figure 9

Item	Description
1	Filter slot 1 (filter holders sold separately)
2	Filter slot 2 (filter holders sold separately)
3	On/off switch
4	Grounding terminal
5	Channel TTL input 365/400 nm (channel shutter)
6	Channel TTL input 450 nm (channel shutter)
7	Channel TTL input 550 nm (channel shutter)
8	Channel TTL input 635 nm (channel shutter)
9	Global TTL input (global shutter)
10	Control Pod socket
11	USB A socket
12	Power socket
13	Status indicator
14	Bootload switch
15	Liquid light guide retention screws

Table 5



pE-400^{max} Control Pod

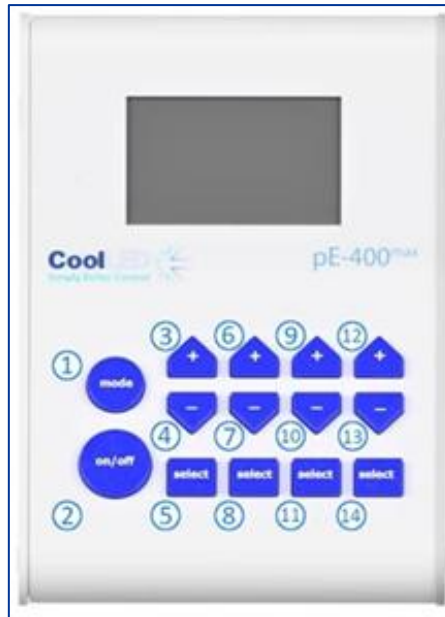

Figure 10

Item	Button Description
1	Mode
2	On/off
3	Increase irradiance channel 1
4	Decrease irradiance channel 1
5	Select channel 1
6	Increase irradiance channel 2
7	Decrease irradiance channel 2
8	Select channel 2
9	Increase irradiance channel 3
10	Decrease irradiance channel 3
11	Select channel 3
12	Increase irradiance channel 4
13	Decrease irradiance channel 4
14	Select channel 4

6. Installation

6.1. Mounting the Light Source

The procedure for mounting your pE-400 Series Light Source to a microscope depends on the light delivery variant.

6.1.1. Direct Fit Light Sources

Attach the Light Sources directly to the epi-illumination port of the microscope using a suitable CoolLED pE-Adaptor.

Note:

- The CoolLED adaptor is specified on ordering and will already be installed on your Light Source. For instructions on how to swap adaptors, e.g., if fitting to a different microscope, please see the next section.
- The exact method of attachment depends on the microscope configuration – please follow microscope manufacturer's instructions.
- The Light Source may be oriented horizontally or vertically to fit the microscope, provided the air vents are not obstructed (Figure 11).
- Optical adjustment is required once installed. Please see Section 9.



Figure 11: Figure 11 – A pE-400^{max} fitted to a microscope in a horizontal orientation

6.1.2. Moving to a Different Microscope

1. To establish which pE-Adaptor is required for your microscope, please visit: www.cooled.com/products/adaptors
2. Insert the pE-Adaptor into the output of the pE-400 Series Light Source (Figure 12).
3. Using a 1.5 mm Hex Key, secure the pE-Adaptor in place by gently fastening the adaptor retention grub screws found at the output of the Direct Fit Light Sources (Figure 13).



Figure 12

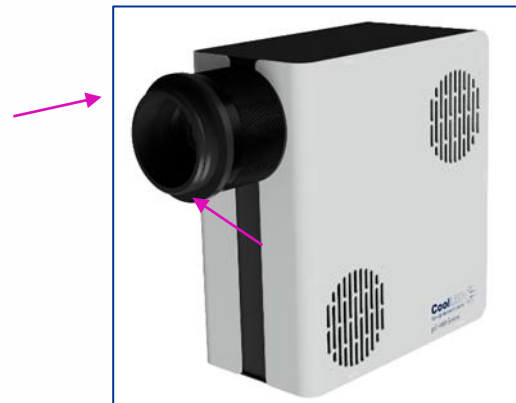

Figure 13

Do not over-tighten the adaptor retention grub screws. Over-tightening may damage the pE-Adaptor or the Light Source and result in an unsafe or poorly performing installation.

6.1.3. Liquid Light Guide Variants

Liquid Light Guide variants of the pE-400 Series accept a 3 mm liquid light guide.

1. Insert a free end of a 3 mm liquid light guide into the Light Source, ensuring that the light guide is fully seated in the Light Source output barrel (Figure 14).
2. While holding the liquid light guide securely in place, use the 1.5 mm Hex Key to gently fasten retention grub screw found at the output of the Light Source (Figure 15).

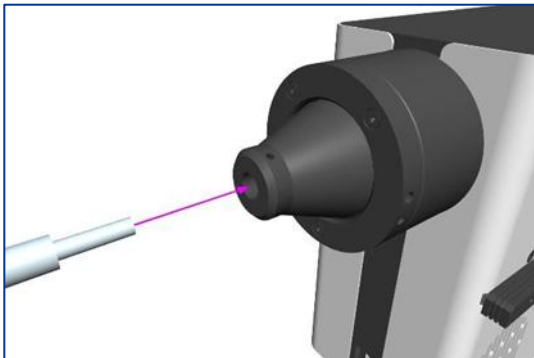

Figure 14

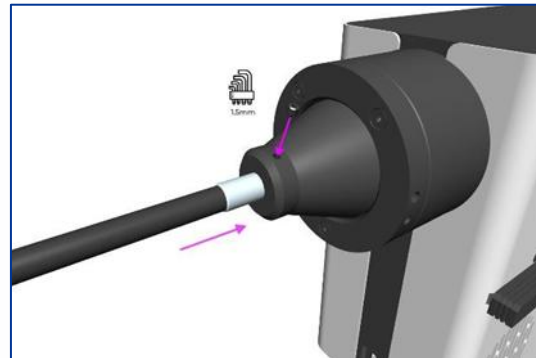

Figure 15

Do not over-tighten the liquid light guide retention grub screws. Over-tightening may damage the liquid light guide or the Light Source and result in an unsafe or poorly performing installation.

3. For microscopes that permit direct liquid light guide insertion, insert and secure the free end as per the microscope manufacturer's instructions.
 - For microscopes that do not permit direct liquid light guide insertion, the free end of the liquid light guide must be fed into a collimator such as the CoolLED pE-Universal Collimator. For information on installation, optical adjustment and moving to a different microscope, please see:

www.cooled.com/products/accessories/pe-universal-collimator

6.2. Electrical Connections

With the pE-400 Series Light Source installed in its final location, the Control Pod and Power Supply must be connected to the Light Source using the following steps.

1. Ensure the on/off switch on the back panel of the Light Source is in the off position.
2. Connect the Control Pod to the Light Source by inserting the Control Pod connector into the pod socket marked on the back panel of the Light Source. Use the markings surrounding the pod socket for correct orientation.
3. Connect the Power Supply to the Light Source by inserting the Power Supply connector into the power socket marked on the back panel of the Light Source. Use the markings surrounding the power socket for correct orientation.
4. Once the pE-400 Series Light Source is mounted to a microscope, ensure that adequate clearance remains at the rear of the unit such that the PSU cable can be removed if required.

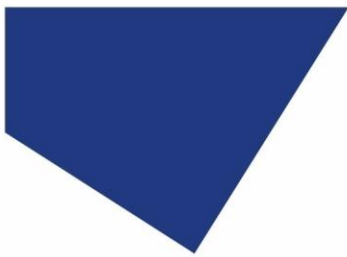

Figure 16: pE-400^{max} back panel showing the On/Off Switch (left), and pod socket and power sockets with surrounding markings to guide orientation of connectors (right).

7. Light Source Control

With the pE-400 Series Light Source installed and connections made, the following steps initiate and modulate illumination. The steps required depend on whether your Illumination System is a pE-400 (with global irradiance control) or a pE-400^{max} with individual channel irradiance control.

7.1. Manual Control Pods

7.1.1. pE-400: Initiating Illumination

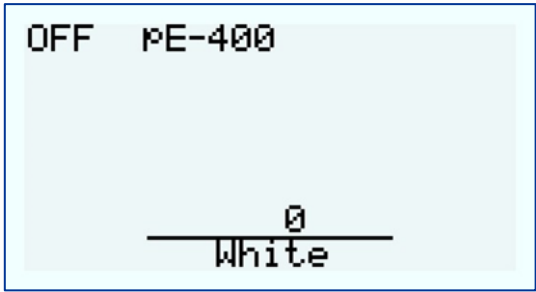
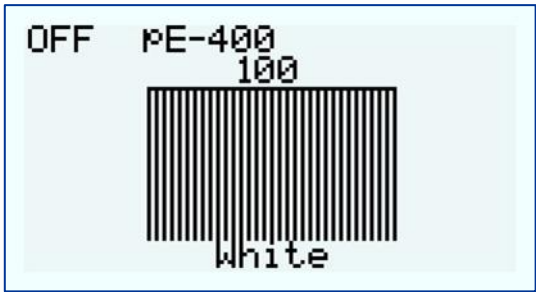
1	Power up your pE-400 Light Source by switching the <i>on/off switch</i> on the back panel of the Light Source to the <i>on</i> position.	
2	Observe the Control Pod booting up. This image shows the Control Pod screen once the boot sequence has concluded.	
3	Use the <i>increase global irradiance button (+)</i> and <i>decrease global irradiance button (-)</i> to input the desired irradiance. The Light Source output is <i>off</i> (extinguished) during this adjustment period ¹ , indicated by the <i>OFF</i> text and striped irradiance bar on the Control Pod.	

4	<p>Press the <i>on/off button</i> once to switch the Light Source output <i>on</i> (illuminated). The ON text and solid irradiance bar on the Control Pod indicate the <i>on</i> state.</p>	
5	<p>Press the <i>on/off button</i> again to extinguish the Light Source.</p>	

7.1.2. pE-400: Display Backlight and Contrast Settings

Adjusting the LCD backlight and contrast settings allows the Control Pod to remain legible but unobtrusive across ambient lighting conditions.

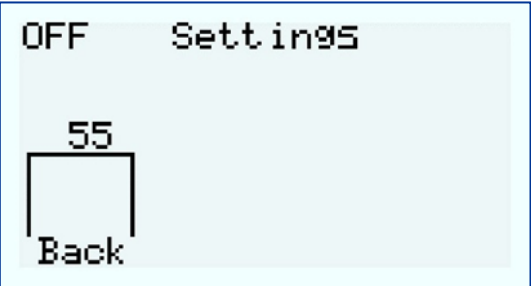
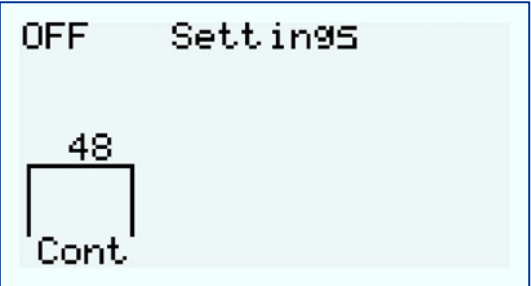
1	<p>Press the 'mode' button for 3 seconds to access the Backlight settings.</p>	
2	<p>Use the 'increase global irradiance' button (+) and 'decrease global irradiance' button (-) to adjust the Backlight.</p>	
3	<p>Press the 'mode' button to access the Contrast settings.</p>	
4	<p>Use the increase global irradiance button (+) and decrease global irradiance button (-) to adjust the Contrast.</p>	
5	<p>To return to the main screen, either press and hold the 'mode' button for 3 seconds or wait for 10 seconds and the screen will return automatically.</p>	

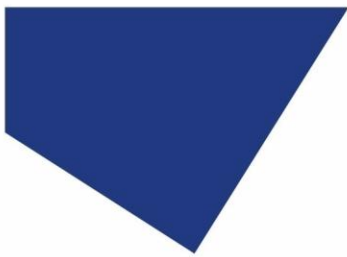

7.1.3. pE-400^{max}: Initiating Illumination

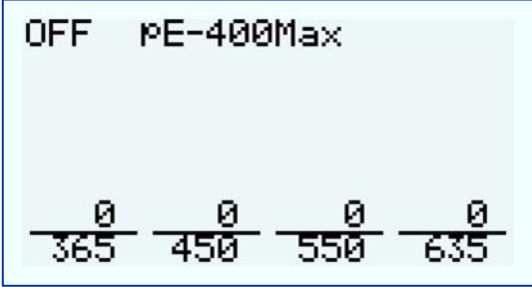
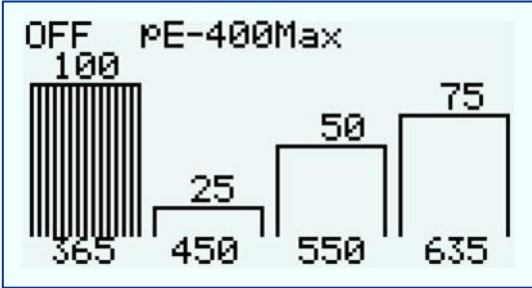
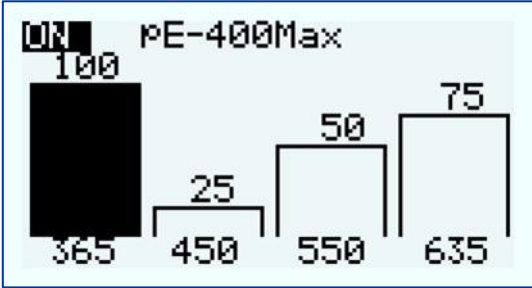
1	Power up your pE-400 ^{max} Light Source by switching the <i>on/off</i> switch on the back panel of the Light Source to the <i>on</i> position.	
2	Observe the Control Pod booting up. This image shows the Control Pod screen once the boot sequence has concluded.	
3	Select the channel (or channels) to be illuminated using the select button appropriate for the desired channel.	
4	Use the 'increase irradiance' buttons (+) and 'decrease irradiance' buttons (-) for a channel to input the desired irradiance.	
5	A striped power bar on display indicates any channel which is selected and has an irradiance value greater than zero. The Light Source output is <i>off</i> (extinguished) during this adjustment period, indicated by the OFF. ¹	
6	Press the 'on/off' button once to switch the Light Source output <i>on</i> (illuminated) for all selected channels. The ON text and solid irradiance bar on the Control Pod indicate the <i>on</i> state.	
7	Press the 'on/off' button again to extinguish the Light Source.	

¹The irradiance of the Light Source can be adjusted when the Light Source is either in an *on* or an *off* state. If the output is *on*, changes in irradiance are immediately visible through the microscope eyepiece.

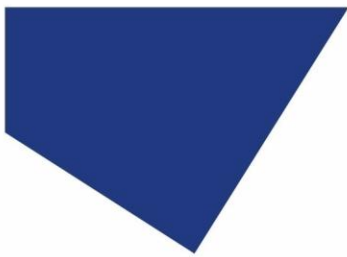

7.1.4. pE-400^{max}: Display Backlight and Contrast Settings

Adjusting the LCD backlight and contrast settings allows the Control Pod to remain legible but unobtrusive across ambient lighting conditions.

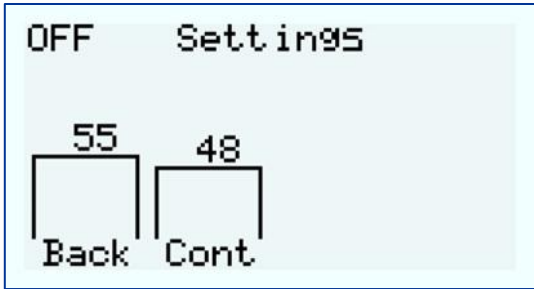
1	Press the 'mode' button for 3 seconds to reveal the Settings screen	
2	Use the 'increase irradiance' button (+) and 'decrease irradiance' button (-) below the <i>Back</i> (Backlight) and <i>Cont</i> (Contrast) columns to increase and decrease the associated settings.	
3	To return to the main screen, either press and hold the 'mode' button for 3 seconds or wait for 10 seconds and the screen will return automatically.	

7.1.5 pE-400 and pE-400^{max} System Information

To access information relating to hardware, software, run-time and diagnostic data, take the following steps:

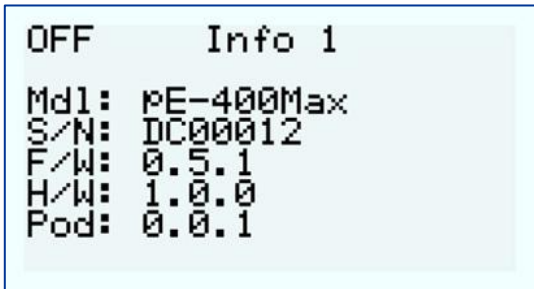
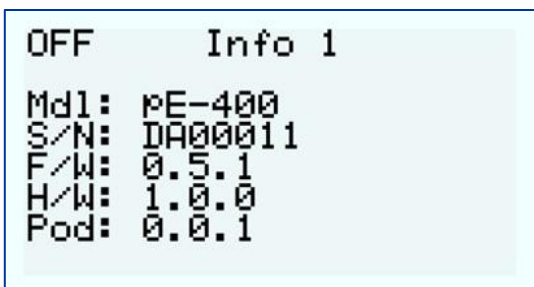
1	Press and hold the 'mode' button for 3 seconds.	
2	Once the display settings screen appears, press the 'mode' button repeatedly to cycle through the available resources.	
3	pE-400 ^{max} firmware and hardware information.	
4	pE-400 firmware and hardware information.	

5	Channel and system runtime information.	<pre> OFF Info 2 635: 7.0h 400: 1.0h 450: 7.0h 550: 18.7h System: 43.2h </pre>
6	Channel diagnostic information.	<pre> OFF Diagnostics L(C) D(C) L(A) 635: 23 25 0.2 400: 24 25 0.3 450: 24 25 0.2 550: 23 25 0.3 Case: 28C </pre>
7	To return to the main screen, either press and hold the mode button for 3 seconds or wait for 10 seconds and the screen will return automatically.	

7.2. TTL Triggering

7.2.1 Global Triggering

All pE-400 Series Light Sources include a Global TTL Input (see Section 5, Reference Diagrams). This provides the facility to control the overall illumination state of the Light Source using a TTL-output from a device such as a camera. Inputting 5 V (high) into the Global TTL Input illuminates all the selected channels, while 0 V (low) extinguishes all channels. Channels can be selected using either the Control Pod, LightBridge or third-party software.

7.2.2. Channel Triggering (pE-400^{max})

pE-400^{max} Light Sources include Channel TTL Inputs (see Section 5.2, pE-400^{max} Light Sources Diagrams), which provide the facility to control the illumination state of the individual channels. Channel TTL inputs operate similarly to the channel selection buttons on the pE-400^{max} Control Pod. When a 5 V (high) trigger is received by the Channel TTL Input, this effectively selects the associated channel in the same way that pressing a selection button does. Receiving 0 V (low) effectively deselects the associated channels. If a TTL high is present on a Channel TTL Input, the associated Light Source Channel will illuminate

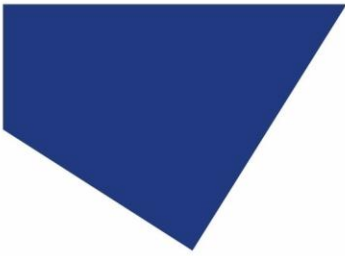

7.3. Software

The pE-400 and pE-400^{max} have USB connectivity for control through imaging software. For more information and to see which third-party software platforms support the pE-400 Series, please visit: www.cooled.com/support/imaging-software.

7.4. pE-400^{max} LightBridge

pE-400^{max} LightBridge is a Windows PC application developed by CoolLED. The application controls pE-400^{max} Light Sources and is not compatible with any other CoolLED Light Sources. LightBridge shares many of the control features found on the pE-400^{max} Control Pod (for example, irradiance control and channel selection) but adds advanced configuration options like boot control.

7.4.1. Reference Diagram

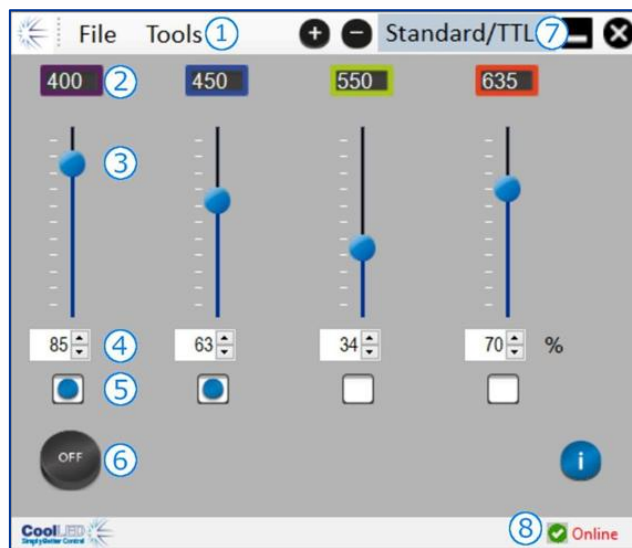

Figure 17: pE-400^{max} LightBridge

1	Tools dropdown menu
2	Channel wavelength indicator
3	Channel irradiance slider
4	Numeric channel irradiance control
5	Channel select control box
6	ON/OFF status Indicator button
7	Mode select dropdown menu
8	Light source status indicator

Table 6

7.4.2. Illuminating the pE-400^{max}

The following steps must be taken to illuminate the pE-400^{max} using LightBridge.

1. Install the pE-400^{max} LightBridge from the accompanying USB stick, or:
www.cooled.com/support/imaging-software
2. Connect the pE-400^{max} Light Source to a Windows PC running LightBridge.
3. Check that the Light Source Status indicator shows as 'Online'.
4. Input the desired channel irradiances by either:
 - Sliding the channel irradiance sliders
 - Clicking the up and down arrows of the numeric channel irradiance controls.
 - Keying values into the numeric channel irradiance control boxes.
5. Select the required channels by clicking the channel select control boxes.
6. Click the ON/OFF status indicator button to illuminate the Light Source.
7. Click the ON/OFF status indicator button a second time to extinguish the Light Source.
8. Note that the ON/OFF status indicator button serves as a Light Source control and a Light Source illumination status indicator. Clicking the button toggles the illumination state of the Light Source. When the Light Source is illuminated, the button is blue and labelled ON. When the Light Source is extinguished, the button is grey and labelled OFF.

7.4.3. Power-Up Configuration

LightBridge provides the facility to configure the operating state of the pE-400^{max} when it powers up. By default, a pE-400^{max} Light Source powers up in the following configuration:

- The Light Source is in an 'off' state
- All the channel irradiance values are set to zero
- All the channels are deselected

Using the Power Up Configurator found in the Tools dropdown menu (see 7.4.1. Reference Diagram), the channel selection, channel irradiance and the Light Source state after boot-up can be configured and saved. To set the power-up configuration, the following steps must be taken:

1. Enter the required channel irradiance by clicking the up and down arrows of the numeric channel irradiance controls.
2. Select the required channels by clicking the channel select control boxes.
3. Select the Light Source power-up state using the dropdown box (see Figure 18 to Figure 20).

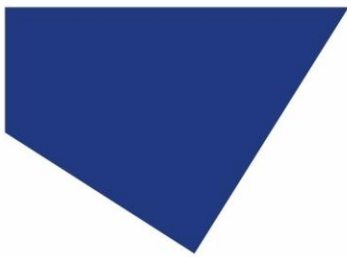

4. Click the Save and Exit button.
5. Note that clicking the Exit button escapes the Light Source Power Up Configuration window without saving any settings.
6. Table 9 summarises the possible pE-400^{max} Power-Up configurations.

Power Up Configuration	Channel Selection	Channel Irradiance	Light Source State
Disabled (Default)	None	0%	OFF
Irradiance level set, LEDs off	Saved	Saved	OFF
Irradiance level set, LEDs on	Saved	Saved	ON

Table 7

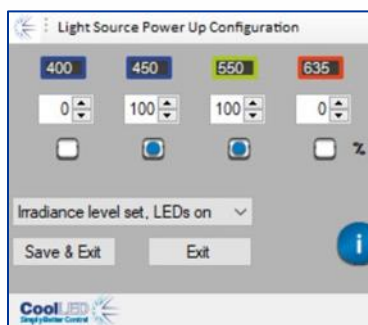

Figure 18

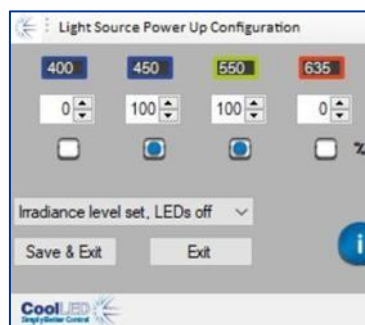

Figure 19

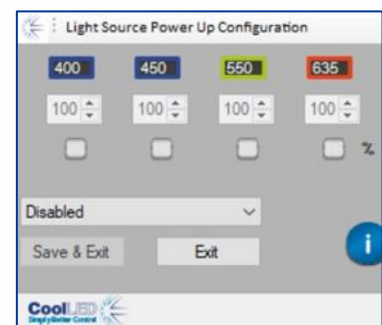
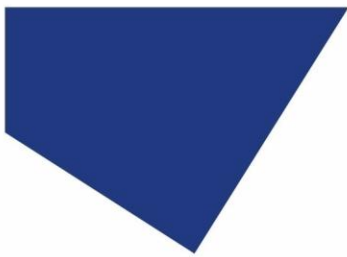



Figure 20



7.5. Sequence Runner (pE-400^{max})

The pE-400^{max} allows sequential illumination of individual Light Source channels. This sequence cycles through automatically, with triggering synchronised via the global TTL input of the pE-400^{max} and a single TTL output from a camera or other hardware. When operating in Sequence Runner mode, a TTL trigger signal injected into the global TTL input causes the Light Source to extinguish any illuminated channels and illuminate the next channel in the sequence. Once the TTL input is connected to the global TTL input of the pE-400^{max}, Sequence Runner can be configured on the Control Pod or LightBridge.

7.5.1. Configuring Sequence Runner on pE-400^{max} Control Pod

1	Access Sequence Runner mode by quickly pressing the 'mode' button on the pE-400 ^{max} Control Pod.	
2	The Control Pod displays the sequence number and irradiance value of all channels above the channel column.	
3	Pressing a 'channel select' button selects and deselects the associated channel, indicated by the vertical stripes.	
4	The order in which channels are selected and deselected determines the order that channels illuminate when a TTL signal is injected. The sequence number displays the final sequence.	
5	Pressing the increase irradiance button (+) and decrease irradiance button (-) on the Control Pod sets the irradiance value of the associated channel.	

6	With the order and irradiance values set, pressing the on/off button on the Control Pod initiates the sequence.
7	Note that while a sequence is in progress (ON), changes to the channel order and irradiance are prohibited, and the TTL inputs associated with the individual channels are disabled.

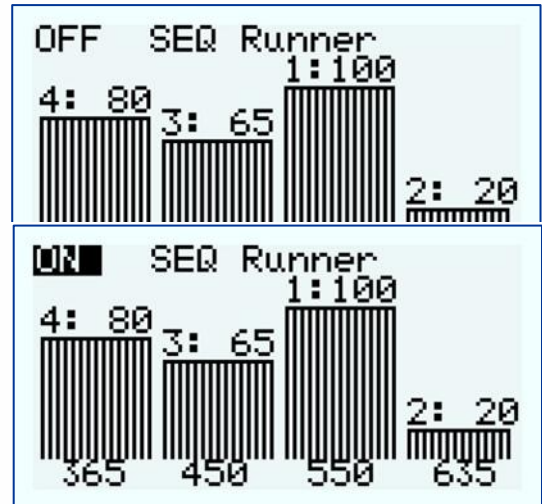

7.5.2. Configuring Sequence Runner in pE-400^{max} LightBridge

1	Sequence Runner mode can also be accessed by accessing the tools dropdown menu and selecting Sequence.	
2	Select the desired channels using the Channel Select Control Box. The order in which channels are selected and deselected determines the order that channels illuminate when a TTL signal is injected. The sequence number is displayed next to the Channel Select Control Box.	
3	Input the desired irradiances by either: <ul style="list-style-type: none"> • Sliding Channel Irradiance sliders • Clicking up and down arrows of the Channel Irradiance controls. • Keying values into the Numeric Channel Irradiance Control Boxes. 	

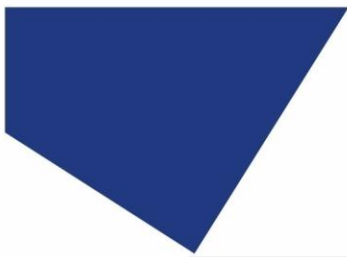

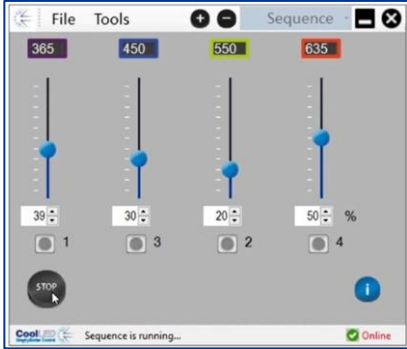
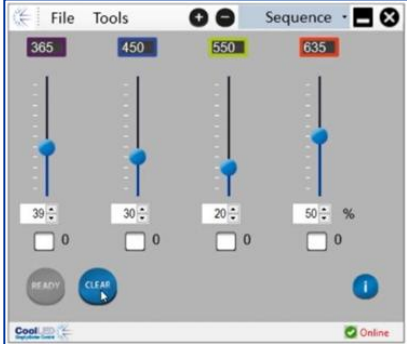
4	<p>Click the Ready Button to initiate the Sequence, and Sequence is running... will show as the sequence is in progress.</p>	
5	<p>Note that while a sequence is in progress, changes to the channel order and irradiance are prohibited, and the TTL inputs associated with the individual channels are disabled.</p>	
6	<p>Click the Stop Button to Stop the Sequence. To re-configure the Sequence, click clear to clear the sequence order while maintaining irradiance values.</p>	

8. Excitation Filters (pE-400^{max})

pE-400^{max} Light Sources (only) can accept 32 mm and 25 mm excitation filters with the purchase of optional excitation filter holders and excitation filter adaptor rings. For information on the applications and benefits of this feature, please see:

www.cooled.com/products/pe-400max.

Excitation filter holders natively accept 32 mm excitation filters, while 25 mm excitation filters must be installed into an adaptor ring before being fitted into the filter holder.

8.1. Excitation Filter Installation Procedure

To install excitation filters into a pE-400^{max} Light Source, the following steps must be taken:

1. Remove the excitation filter covers from the pE-400^{max} Light Source by unscrewing the M3 hex retaining screws using a 1.5 mm hex key (Figure 21).
2. Loosen the two filter retaining screws on the excitation filter holder using a 1.5 mm hex key (Figure 22). The retaining screws should not be removed.
3. Remove the excitation filter adaptor rings from the excitation filter holder (Figure 23).
4. Ensure the correct orientation of filter holders. There is a label on one side which must face the LEDs and air vents (Figure 24).
5. For installing 32 mm excitation filters, insert these directly into the excitation filter holder (Figure 25). Most excitation filters have a directional arrow on the side, and this must point towards filter holder.
6. If 25 mm excitation filters are to be installed, filters must first be securely installed inside an adaptor ring by gently fastening the filter retention screws on the adaptor ring (Figure 26) before being inserted into the excitation filter holder (Figure 27).
7. With the filters installed in the filter holder, gently fasten the retaining screws (Figure 28).

Warning: Do not over-tighten the excitation filter holder or adaptor ring retention screws. This may permanently damage the excitation filter, the Light Source or both.

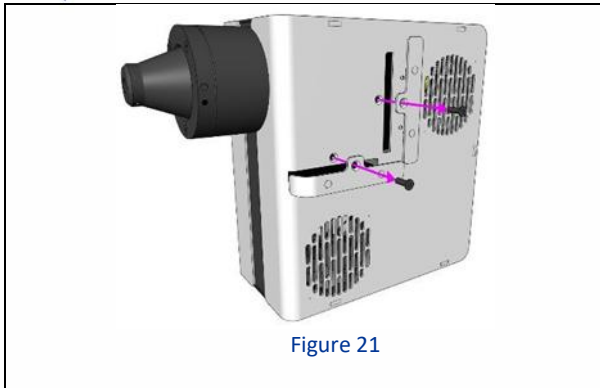
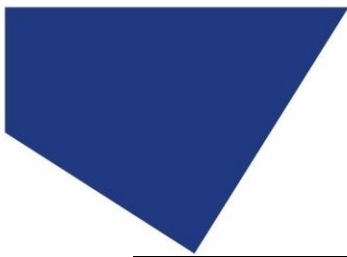

Figure 21

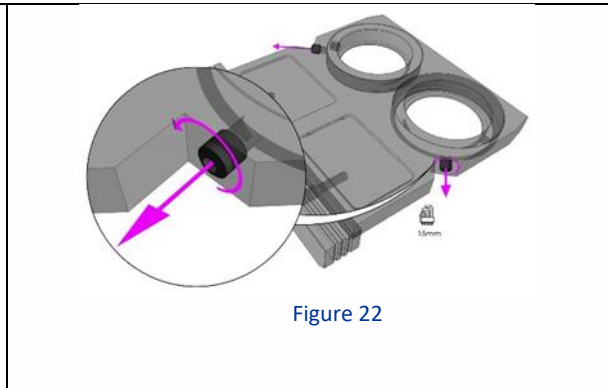

Figure 22

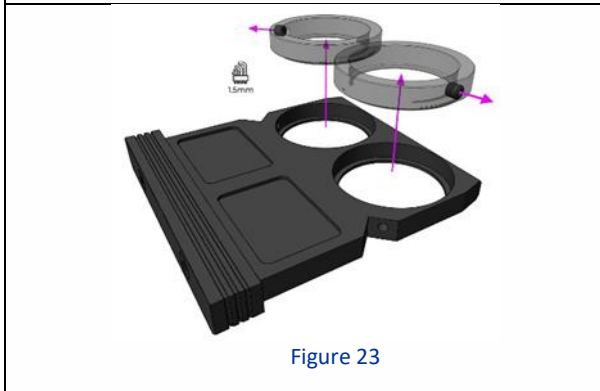

Figure 23



Figure 24

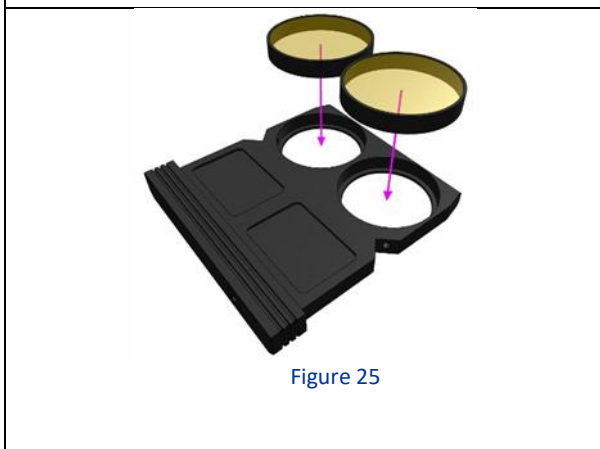

Figure 25

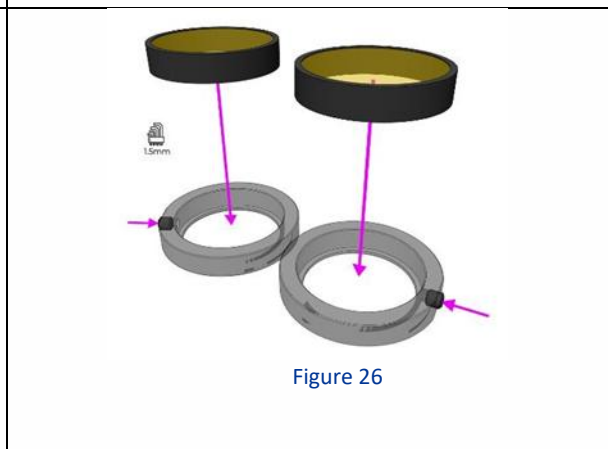

Figure 26

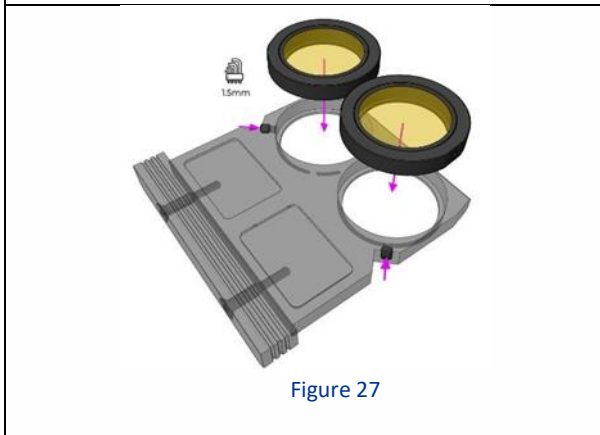

Figure 27

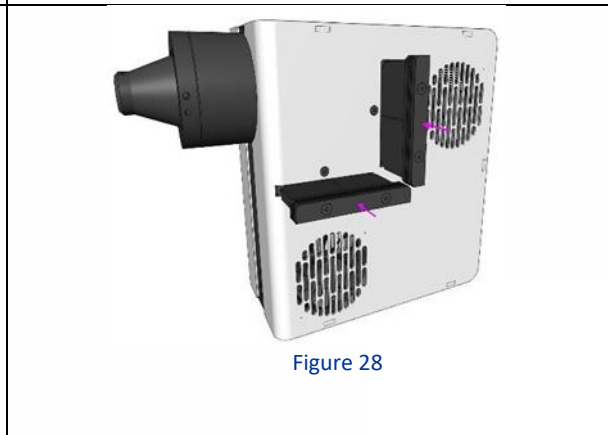

Figure 28

9. Optical Adjustment

Direct Fit pE-400 Series Light Sources must be adjusted to deliver bright, homogeneous illumination. Optimising the pE-400 Series Light Source is achieved using the light output barrel, using the following steps:

1. Loosen the grub screws on the light output barrel (Figure 29, arrow).

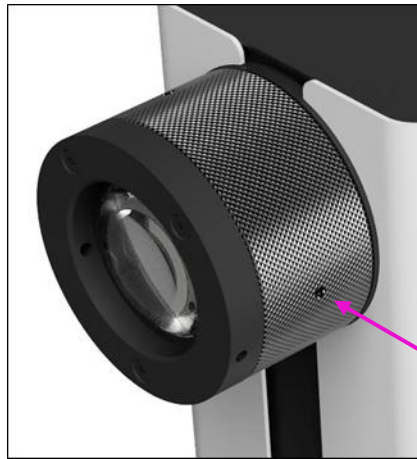

Figure 29: A pE-400 Series Direct Fit Light Source optical adjustment achieved by twisting the light output barrel. Grub screws (cyan arrow) must first be loosened.

2. Once the light source is attached to the microscope, whilst looking through the eyepiece of the microscope and focused on a reference slide or sample, rotate the barrel until optimal homogeneity is reached:



Figure 30: (From left to right) An underfilled sample plane (focus adjustments required), a central bright spot (focus adjustments required), most homogenous (optimal focus).

3. With optimum focus achieved, fasten the grub screws to retain the position.

10. Product Options and Order Codes

Please see www.cooled.com for full details of product options and order codes.

11. Warranty and Repairs

Please refer to CoolLED's Warranty Policy available on the company website:

www.cooled.com/support/cooled-warranty/

Although warranty terms are fixed at the time of ordering according to the terms and conditions of sale in place, the Warranty Policy may be subject to periodic change, so please contact us to avoid confusion. For any warranty queries or in the event of the product developing a fault, email support@cooled.com for assistance. You will be asked to provide your microscope make and model, the Light Source serial number and a description of the problem.

12. Compliance

12.1 WEEE

All qualifying products that are subject to the WEEE Directive and supplied by CoolLED are compliant with the WEEE marking requirements. Such products are marked with the "crossed out wheelee bin" WEEE symbol and in accordance with European Standard EN 50419. CoolLED Certificate No: WEEE/GB4236XX

12.2 RoHS

Based on information obtained from our component suppliers, this statement certifies that ALL products manufactured and supplied by CoolLED Ltd are in compliance with Directive 2011/65/EU of the European Parliament and of the Council of 8 June 2011 on the restriction of the use of certain hazardous substances in electrical and electronic equipment (also known as RoHS). This declaration is correct to the best of CoolLED Ltd's knowledge, information and belief at its release date.

13. Recycling

At CoolLED, we recognise the importance of preserving the environment and are proud to offer a Recycling Program to our customers. The CoolLED Recycling Program is a free service that permits customers to return any CoolLED Light Sources to CoolLED for recycling once it has reached the end of their useful life. The program is designed to reduce the burden on our environment through the responsible disposal and recycling of End-of-Life Light Sources. To participate in the program, complete our online contact form found at www.cooled.com/contact/contact-form and provide us with your contact details and the serial number of the CoolLED Light Source you wish to recycle. CoolLED will arrange for the collection of the Light Source free of charge. If you are taking delivery of a replacement CoolLED Light Source, why not send the old one back in the packing box of the new one?

14. Contact Details

ADDRESS	CoolLED Limited
	26 Focus Way
	Andover
	Hampshire
	SP10 5NY
	United Kingdom
PHONE	+44 (0)1264323040
EMAIL	info@cooled.com
WEBSITE	https://www.cooled.com

15. Product Specifications

SUPPORTED OPERATING SYSTEMS	
Compatible Operating Systems	Windows 11
	Windows 10
	Earlier Windows versions (with CoolLED pE-Driver)
POWER	
Input Voltage & Frequency	100 to 240 VAC, 50/60 Hz - PSU 12VDC 8.5A - Light Source
Maximum Input Voltage Fluctuation	±10%
Power Consumption	80 Watts (max) 2 Watts (Idle)
Power Supply	Meanwell GS120A12-R7B
DIMENSIONS	
pE-400 Direct Fit	243 x 197 x 102 mm
pE-400 Liquid Light Guide	274 x 197 x 95 mm
pE-400 ^{max} Direct Fit	243 x 197 x 102 mm
pE-400 ^{max} Liquid Light Guide	274 x 197 x 95 mm
pE-400 ^{max} Direct Fit (filter holders installed)	243 x 197 x 104 mm

pE-400 ^{max} Liquid Light Guide	274 x 197 x 104 mm
pE-400 Control Pod	125 x 90 x 40 mm
pE-400 ^{max} Control Pod	125 x 90 x 40 mm
WEIGHTS	
pE-400 Direct Fit	1.8 kg
pE-400 Liquid Light Guide	1.9 kg
pE-400 ^{max} Direct Fit	2.1 kg
pE-400 ^{max} Liquid Light Guide	2.2 kg
pE-400 ^{max} Direct Fit (filter holders installed)	2.1 kg
pE-400 ^{max} Liquid Light Guide (filter holders installed)	2.2 kg
pE-400 Control Pod	0.3 kg
pE-400 ^{max} Control Pod	0.3 kg
ELECTRICAL	
TTL Input High (V _{IH})	2.7 V ≤ V _{IH} ≤ 12 V
TTL Input Low (V _{IL})	0 V ≤ V _{IL} ≤ 1.6 V
OPERATING ENVIRONMENT	
Temperature	10 – 35°C
Relative Humidity	0 – 90%
COMPLIANCE	
Emissions & Immunity	EN 61326-1:2021 Electrical equipment for measurement, control and laboratory use – EMC requirements. Part 1: General requirements.
Photobiological	EN 62471:2008 Photobiological safety of lamps and lamp systems

16. Appendix

16.1. Boot Load Procedure

Occasionally it may be necessary to upgrade the firmware of the pE-400 Series Light Source. Should an upgrade be required, please contact support@cooled.com to secure the required binary (firmware) file and instructions.